

tousek Rollco® LWA 115

Aluminium
Cantilever Systems for
Sliding Gates *rational & flexible*

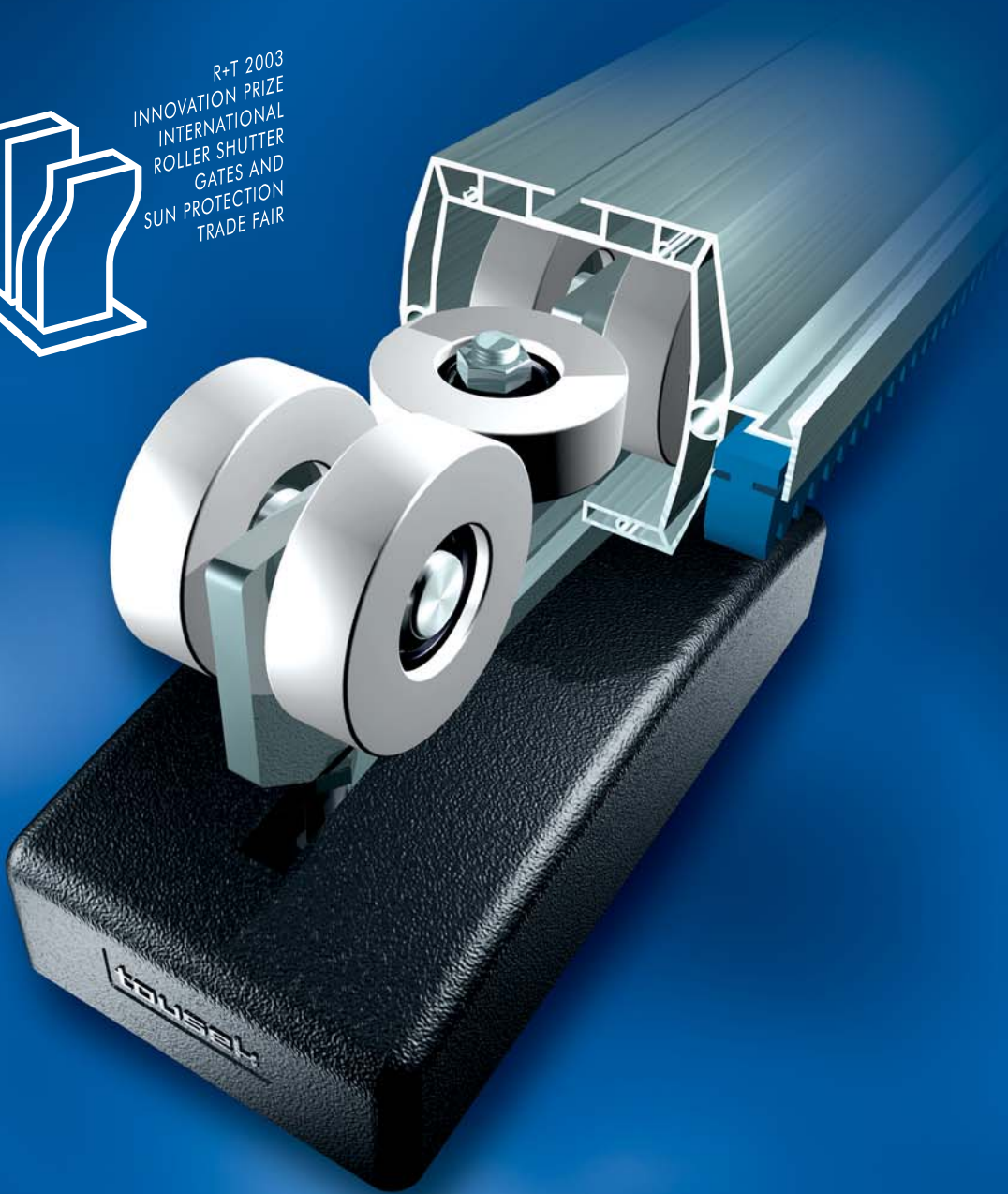

R+T 2003
INNOVATION PRIZE
INTERNATIONAL
ROLLER SHUTTER
GATES AND
SUN PROTECTION
TRADE FAIR



Sliding gate operators



Cantilever sl. gate sys.



Swing gate operators



Garage door operators



Barrier operators



El. gate control



Impulse emitters



Safety devices



Miscellaneous



tousek[®]
G A T E A U T O M A T I O N

MADE IN AUSTRIA

tousek Rollco® LWA 115



Maintenance-Free Aluminium Systems for all cantilevered sliding gates

- maximum quiet running ■ absolutely corrosion-resistant
- convenient to install ■ hollow-chamber construction type



with up to 5.8 metres passage width



Quiet

The aluminium rail, combined with the solid roller unit and the large polyamide rollers (ballbearing-cushioned) guarantees the greatest quiet while running.



Rational

The technically innovative cantilever systems profile makes installing the gear rack and limit switch time-saving and rational.



Flexible

The roller units, adjustable in height and angle, completely eliminate load alternation reactions.



Enduring

Using aluminium and stainless steel guarantees absolute corrosion resistance.

The unique rail allows the gear rack and gate set-up to be mounted rationally on the aluminium rail without drilling, which saves much time.



Compatible

The Rollco® LWA 115 has been designed to be optimally compatible with the Tousek Pull sliding gate series; of course, it can also be operated manually.

Kompatibel

Das Rollco® LWA 115 ist in seiner Ausführung optimal auf die tousek Schiebetorantriebsserie Pull abgestimmt. Selbstverständlich kann das Rollco® LWA 115 auch von Hand betrieben werden.



The Rollco® LWA 115 is the result of a brand-new concept. The high-quality aluminium rail guarantees absolute corrosion resistance and is about 2/3 lighter than usual steel rails. The solid roller unit, with its large polyamide rollers (ballbearing-cushioned) guarantees maximum quiet while running, even at highest load, as well as reliability for many, many years.

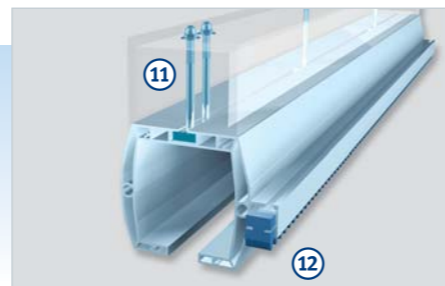

- ① Aluminium rail
- ② 2 Roller devices
- ③ Motor mounting plate for tousek sliding gate operators
- ④ aluminium end plates
- ⑤ limit stops with rubber bumper
- ⑥ limit stops with rubber bumper and support roller
- ⑦ aluminium guide-in bracket
- ⑧ stainless steel guide bracket
- ⑨ stainless steel turnbuckle
- ⑩ stainless steel guide-in fork bracket
- ⑪ stainless steel hammerhead screws
- ⑫ plastic gear rack

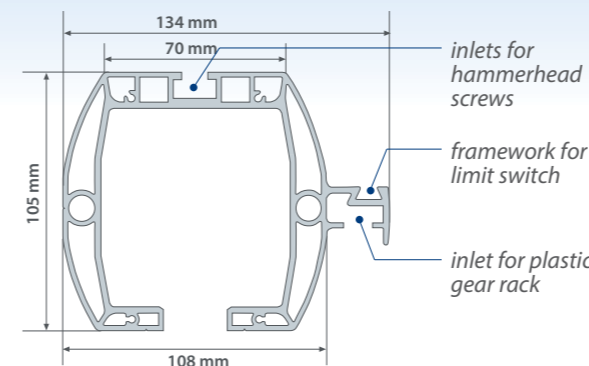

tousek Rollco® LWA 115 sliding-gate system

	material	profile	passage width
frame measurements	aluminium	108/105 mm	4.300mm max. 3.000mm
surfaces	natural aluminium	6.000mm	max. 4.300mm
carrying power	30 kg/lfm	8.000mm	max. 5.800mm
gate frequency	50 cycles/day		
weight	ca. 5 kg/lfm		

See the list of specifications for more detailed information. We reserve the right to change specifications.

Note: Please be aware that the gate-security devices shown in this brochure are examples and are not to be considered as guidelines with regard to applicable standards. The standards in effect in each country must be complied without fail during start-up and/or installation.



Eduard Tousek

For many years now,

we have been working on developing gate operators and their accessories at the forefront in the international field. Expertly trained employees and comprehensive service are two of the factors in satisfying customers' wishes.



tousek - the original

The **Original tousek Quality** certificate is your absolute guarantee of the highest quality when you purchase a **tousek** operator.



Reliable and secure

Tousek's leading technical development, including the Rolling Code Radio System, for instance, which generates a new radio code every time the remote control is activated, thus preventing the radio signal from being scanned by unauthorised persons, is your guarantee of greater security, in demand today as part of seamlessly protecting property. The quality of **tousek** products is guaranteed by the most stringent tolerances in manufacture and constant monitoring.

Compatibility

Tousek places great emphasis on keeping all elements of the gate operator, accessory and security programmes compatible as the assortment of products grows.



www.tousek.com

Your **tousek** partners will be happy to advise you personally.



Subject to changes in design, composition, technical alterations and printing errors. All contents are protected by copyright. Reprinting, digital reproduction, in whole or in part, without our written permission is forbidden.



tousek swing gate operators
rational and strong



tousek barrier systems
attractive and robust



tousek sliding-gate operators
compact and safe



tousek impulse emitter programmes
compatible and secure



www.tousek.com

Visit our website for more important information all about automatic operators.

tousek PRODUCTS

- Sliding-gate operators ▲
- Swing-gate operators ▲
- Garage-door operators ▲
- Folding-gate operators ▲
- Barriers ▲
- Parking systems ▲
- Electronic controls ▲
- Radio remote controls ▲
- Key switches ▲
- Access control ▲
- Security devices ▲

tousek Ges.m.b.H. headquarters

A-1230 Wien, Zetschegasse 1
Tel: +43/ 1/ 667 36 01
Fax: +43/ 1/ 667 89 23
Email: info@tousek.at

tousek GmbH

D-83395 Freilassing
Traunsteiner Straße 12
Tel: +49/ 8654/ 77 66 - 0
Fax: +49/ 8654/ 57 196
Email: info@tousek.de

tousek GmbH

CH-6275 Ballwil
Bahnhofstraße 14
Tel: +41 41/448 29 65
Fax: +41 41/448 29 66
Email: info@tousek.ch

tousek Benelux NV

B-3930 Hamont-Achel
Buitenheide 2A / 1
Tel: +32 11 91 61 60
Fax: +32 11 91 61 60
Email: info@tousek.nl

tousek Sp. z o.o.

PL-43-190 Mikołów (k/Katowic)
Gliwicka 67
Tel: +48/ 32/ 738 53 65
Fax: +48/ 32/ 738 53 66
Email: info@tousek.pl

tousek s.r.o.

CZ-130 00 Praha 3, Jagellonská 9
Tel: +420/ 222 090 980
Fax: +420/ 222 090 989
Email: info@tousek.cz