

Installation- and Operating Instructions

Underfloor operator TURN 310 UF

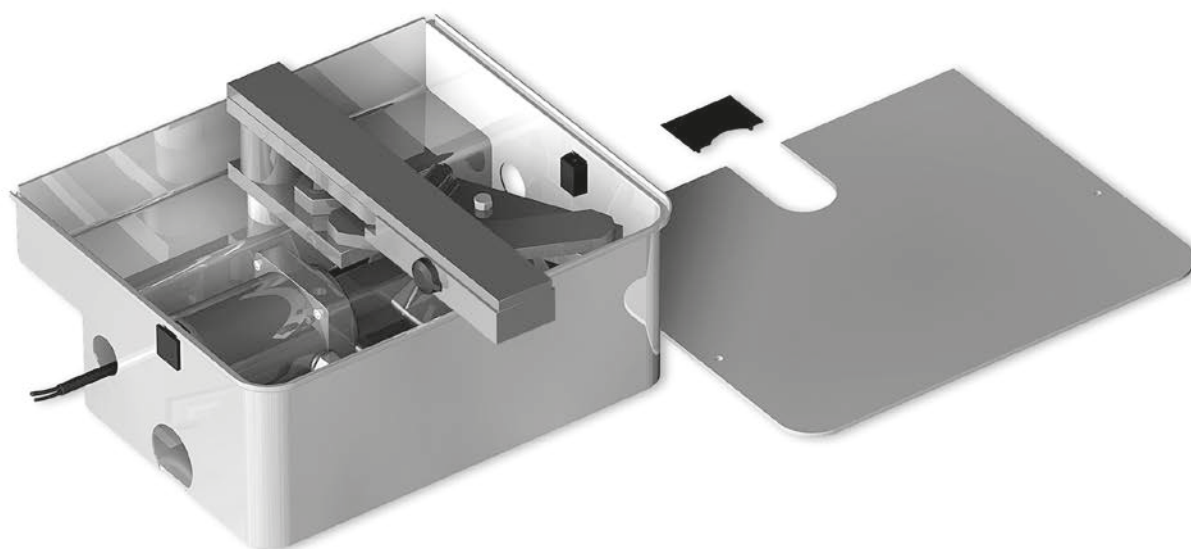



Important warning and safety notes for installation and operation

- These installation- and operating instructions form an integral part of the product “sliding gate operator”. They have been specifically written for professional installers trained and skilled in the trade and should be carefully read in their full length before carrying out the installation. They describe the proper installation and operation of the sliding gate operator only, not of the overall device “automatic gate”. After the installation this manual has to be handed over to the user.
- Installation, connection, adjustments, putting into operation, and servicing may only be carried out by trained professionals in full accordance with these installation- and operating instructions.
- Before carrying out works at the gate-system, the power supply has to be turned off.
- The EU Machine Directive, laws and rules concerning the prevention of accidents, and laws and standards which are in force in the EU and in the individual countries have to be strictly followed.
- The TOUSEK Ges.m.b.H. cannot be held liable for any claims resulting from disregards of the laws and standards in force during the installation and operation.
- The packaging materials (cardboard, plastic, EPS foam parts and filling material etc.) have to be properly disposed of in accordance with the applying recycling- and environmental protection laws. They may be hazardous to children and therefore have to be stored out of children’s reach.
- The product is not suitable for installation in explosion-hazardous areas.
- The product may only be used in accordance with its original purpose, for which it has been exclusively designed, and which is described in these installation and operating instructions. The TOUSEK Ges.m.b.H. rejects any liability if the product is used in any way not fully conforming to its original purpose as stated herein.
- Before beginning with the installation the installer has to make sure that all mechanical components of the gate facility, like carrier profile/rail, gate frame and panels, guiding elements etc. are sufficiently supportive and resistant for the purpose of gate automation.
- All electrical installations have to be made in full conformity with the applying rules and laws (e.g. using a fault current circuit breaker, proper grounding etc.).
- An all-pole disconnecting main switch with a contact opening-gap of minimum 3 mm has to be foreseen
- The electric motor heats up during operation. Therefore the device should only be touched after it has cooled off.
- The TOUSEK Ges.m.b.H. rejects any liability for claims resulting from usage of the product in combination with components or devices which do not fully conform to the applying safety laws and rules.
- Only original spare- and replacement parts may be used for repair of the product.
- The installer has to inform the user about all aspects of the automatic operation of the complete gate facility, as well as about emergency operation. The installer further has to supply to the user all instructions relating to the safe operation of the gate facility. The installation and operating instructions also have to be handed over to the user..
- **Please notice that the warranty will not be applicable if the label with the engine number has been removed or damaged.**



Maintenance

- **Before carrying out maintenance works at the gate-system, the power supply has to be turned off.**
- **Maintenance works may only be carried out by qualified personnel.**
- **Check the proper sensitivity setting of the ARS safety reverse system once a month.**
- **Check the proper function of the emergency release mechanism periodically.**
- **Check if all mounting screws are securely fastened periodically.**
- **Remove dirt deposits from the operator and gear rack periodically.**
- **All pivot and bearing points have to be greased periodically.**
- **Maintenance and servicing of the complete gate facility has to be carried out according to the gate builder’s/ installer’s instructions.**
- **At the end of each winter season you should rinse the operator with warm water.**

EU - Manufacturer’s Declaration according Machine Directive 2006/42/EC:

The company TOUSEK Ges.m.b.H., based in Zetschegasse 1, A-1230 Vienna/Austria, hereby declares that the “Swing gate operator TURN 310 UF” is made available only for the purpose of being built into a machine or of being joined with other machines or machine components, and that it may not be put into operation until a declaration of conformity according to the Directive 2006/42/EC has been issued for the whole machine.

The following directives and standards have been applied:

- Low Voltage Directive 2014/35/EU, incl. changes
- Electromagnetic Compatibility Directive 2014/30/EU, incl. changes

January 2019

Characteristics TURN 310 UF

- for 230V a.c.
- max. weight of gate wings 400 kg
- max. wing size 3 m (from wing size of 2,5 m on an e-lock is recommended)
- galvanized sheet steel- or stainless steel housing
- **CE**

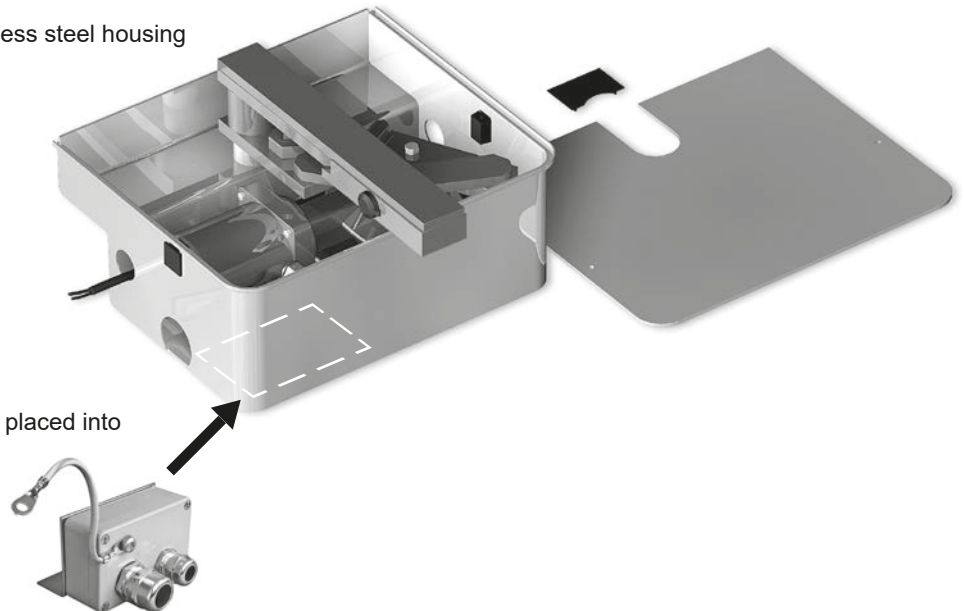

for connection an optional terminal box (IP 66), which will be placed into the operator housing, is available. (see additional manual)

General features

The underfloor operator TOUSEK TURN 310 UF is suitable for the automation of swing gates, whereas the full operating unit is installed under the ground.

This operator was especially developed for swing gates in the private area, which are not exposed to continuous operation. It distinguishes itself by its rather compact shape and the adjustable limit switches which are integrated in its housing.

The motor unit is installed in a massive sheet steel housing, which is optionally also available in stainless steel (TURN 310 UF/E). This housing is constructed the way, that it also serves as bearing for the gate at the same time.

The gate weight (max. 400 kg) is carried by this bearing, and the motor-gearing unit can so be easily removed and installed without dismantling the gate.

The operator ensures the blocking of the gate and so usually no e-lock is required. But according to the individual case of mounting, an additional locking device may be necessary (at wings larger than 2,5 m we recommend the installation of an e-lock).

With a key for emergency release the gate can be opened manually in case of a power failure.

Technical data

| Underfloor operator TURN 310 UF | | | |
|---------------------------------|-------------------------|--|------------|
| operating voltage | 230V a.c., 50Hz | wing weight | max. 400kg |
| current consumption | max. 1,5 A | protection class | IP66 |
| max. turning angle | 110°, optional: 180° *) | Article no. | |
| max. angular velocity | 6° /s | TURN 310 UF | 11230100 |
| max. torque | 300Nm | TURN 310 UF/E (stainless steel) | 11230110 |
| operating factor | 30% | *) additional bracket for 180° opening angle | 14120220 |
| wing size | max. 3m | | |

Other

blocking in open and closed position • force adjustment through control unit • emergency release • internal limit stops • **optional:** steel or stainless steel housing • additional bracket for opening angle > 110° • terminal box IP66



- Max. wing widths do neither apply to full-panel gates (but to stave or trellised gates) nor to non-horizontal gates!
- at wings larger than 2,5 m an e-lock is required!

Technical layout TURN 310 UF

- | | |
|--|--|
| <ul style="list-style-type: none"> 1 underfloor housing 1a bearing pin 1b motor fastening screws (6 x) 1c motor fastening nuts (4 x) 1d opening for connecting cable 1e openings for drainage 2 motor-gearing unit 2a grounding terminal (grounding cable laid separately) 2b gearing shaft mk motor cable 3 motor arm 3a fastening screw 3b adjustable limiting screw (for adjustment of gate position closed) | <ul style="list-style-type: none"> 4 gate driver 4a adjustable limiting hexagon (for adjustment of gate position open) 4b fastening screw 5 lever arm (connects gate driver (4) with motor lever (3)) 6 ball 7 gate bearing 7a emergency release mechanism 7b emergency release lever 8 housing cover 8a fastening screws (2x) 8b intakes for fastening screws (2x) 9 plastic covering |
|--|--|

optional: chain bracket (for turning angle > 110°)

K1 gate driver with pinion **replaces (4)**

K2 output pinion **replaces motor arm (3)**

K3 chain **replaces lever arm (5)**



The U-profile is not part of the delivery. It must be selected suitable to the current gate frame.

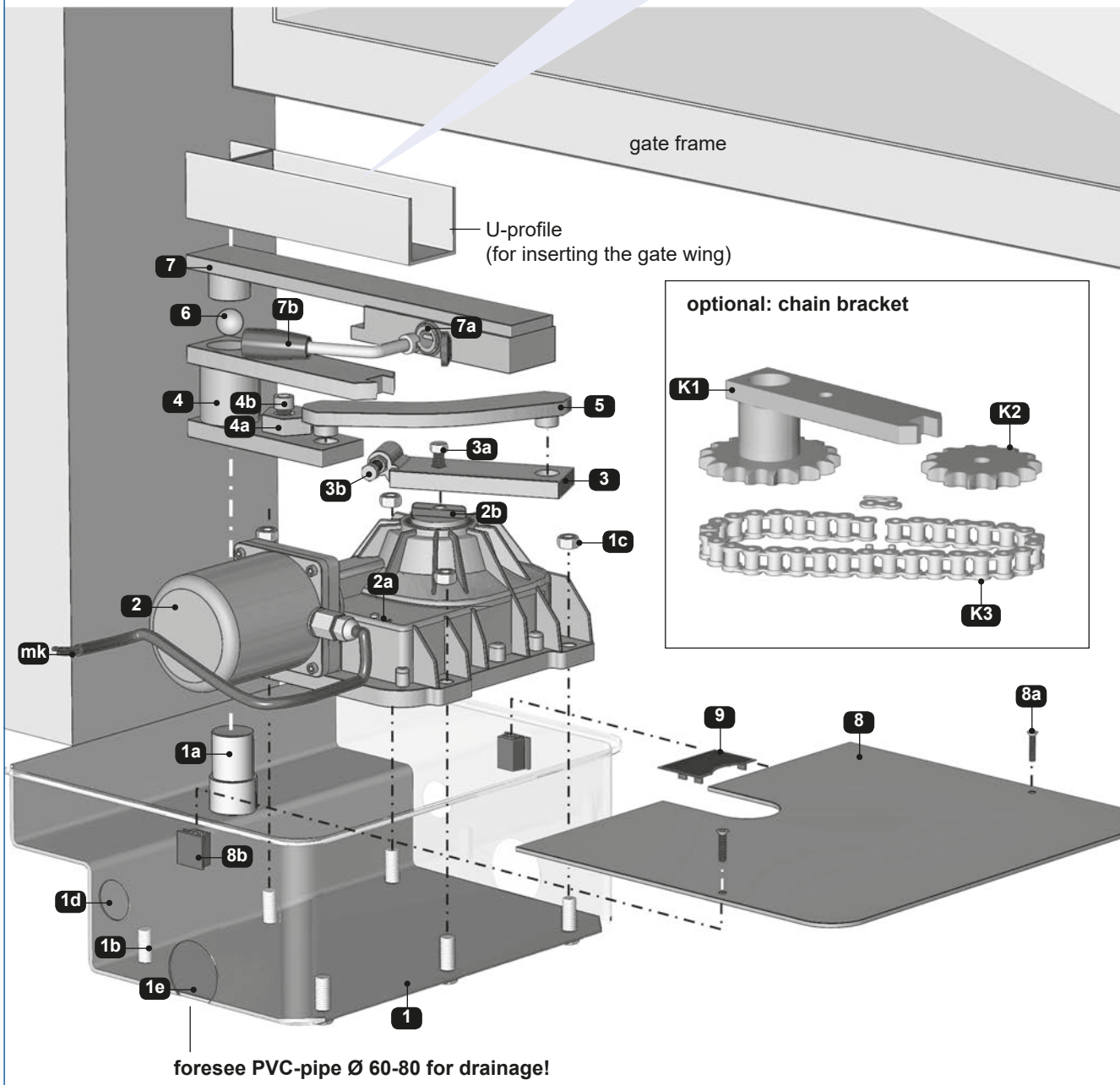



Suggestion

- Before mounting we suggest to spray some protection wax all around the operator.

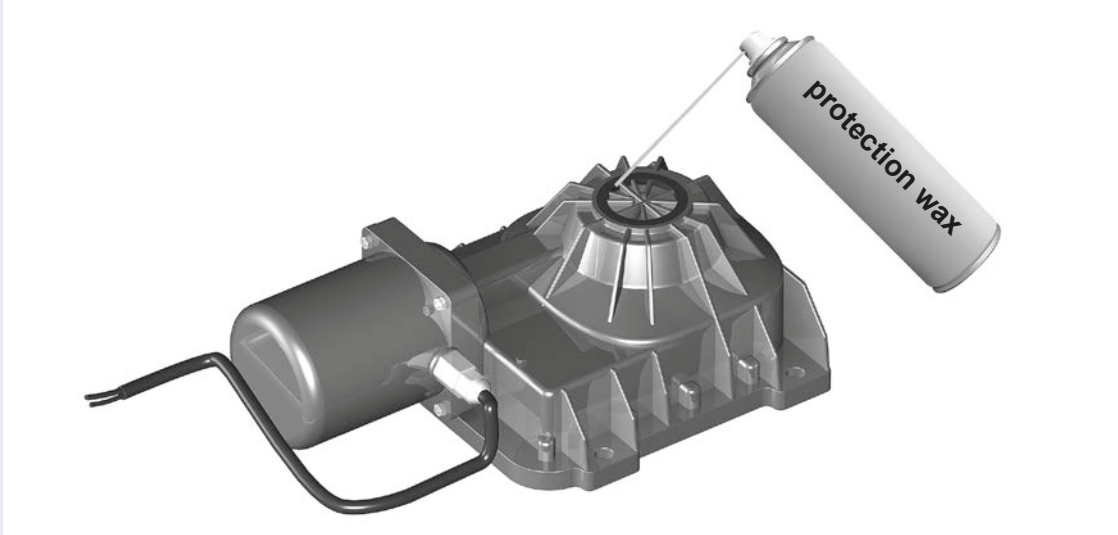

- After mounting please spray some protection wax on all parts inside the operator housing.

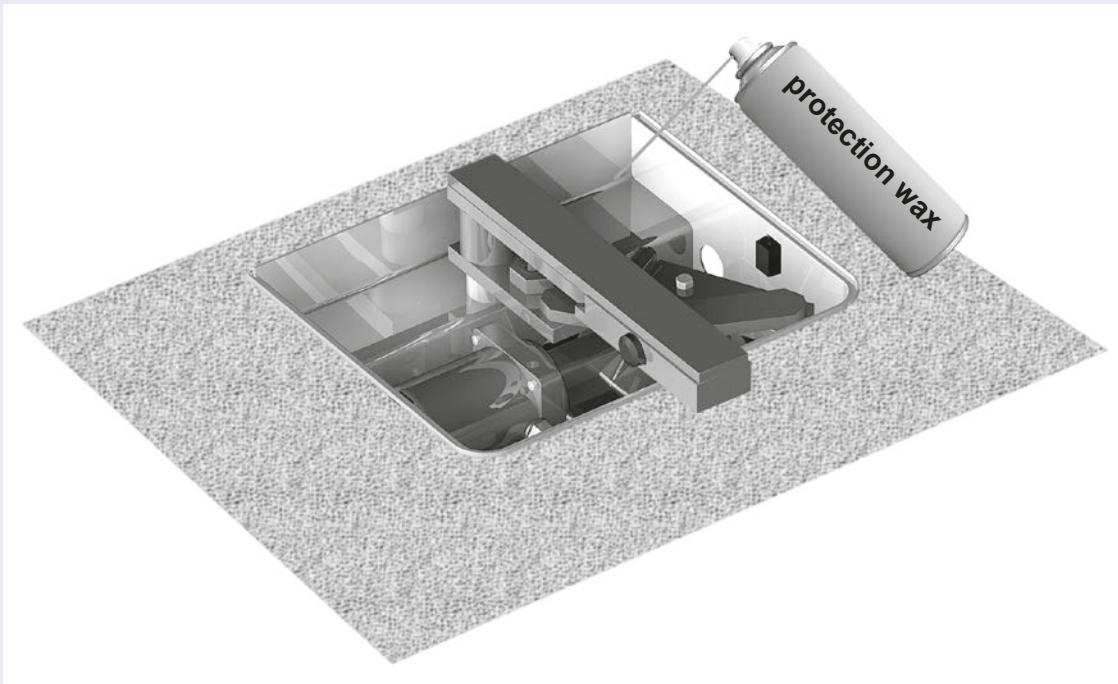

2a. Immuring the underfloor housing

Installation

- Before immuring the operator housing please make take care, that free movement is assured for the full opening angle of the gate.
- At mounting please make sure, that gate hinge and bearing pin of the operator are perpendicular to each other (point A and B).
- Before mounting please remove the motor-gearing unit of the operator housing.
- The operator housing has to be immured in alignment with the ground level and with attention to the below stated measurements in a frost resistant way.
It is absolutely necessary to foresee a drainage!



Important: foresee a drainage!

- To avoid flooding of the operator through strong rainshowers, snowmelt or the like, it is necessary to provide a drainage system for optimal outflow of water.
- For that purpose connect PVC pipes with a diameter of 60–80mm to the provided opening **D** on both sides of the housing.

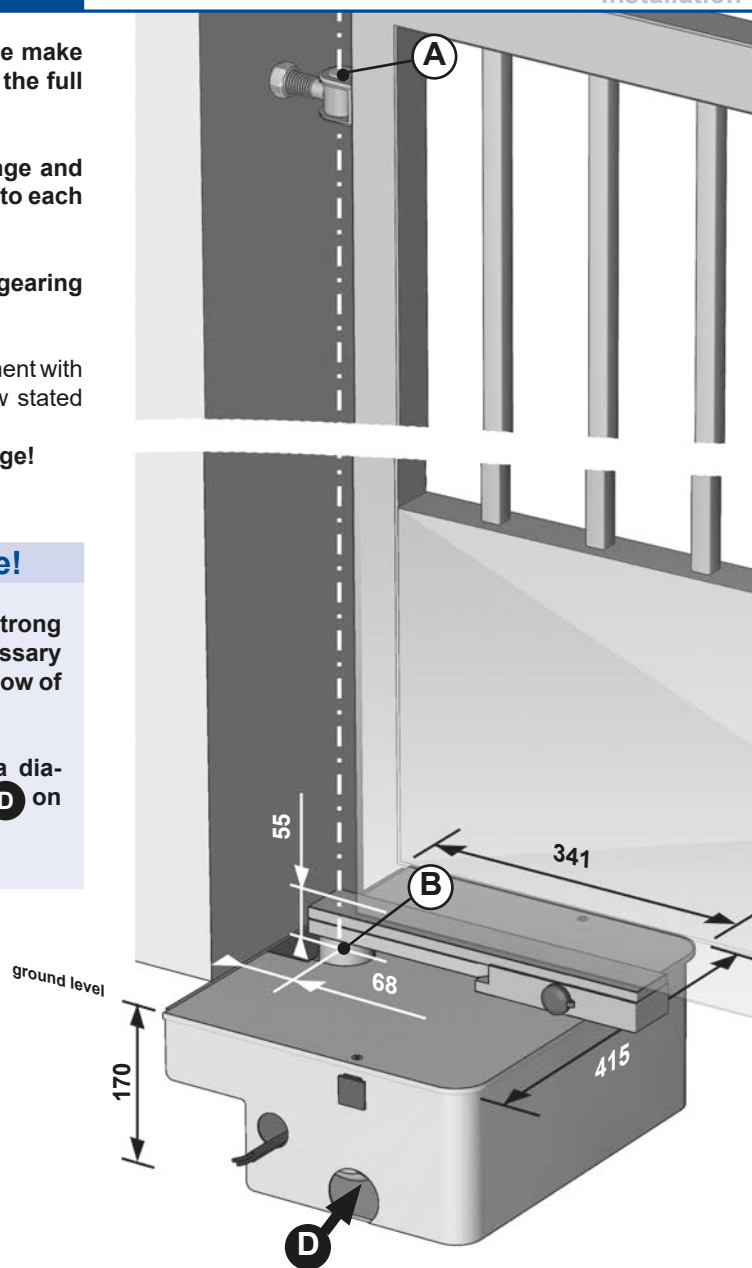

2b. Inserting gate driver and gate bearing

Installation

- **Important: Grease bearing pin (1a)!**
- Put ball (6), gate driver (4) and gate bearing (7) at the bearing pin (1a).

In case that gate driver and gate bearing have not been assembled, insert the gate bearing (7) in the gate driver (4) so that they form one unit.

Therefore the gate bearing (7) is turned in emergency released state (see *emergency release*), till it is aligned at the gate driver (4) as shown in the beside picture and the lever of the emergency release mechanism (7a) may engage in the gate driver.

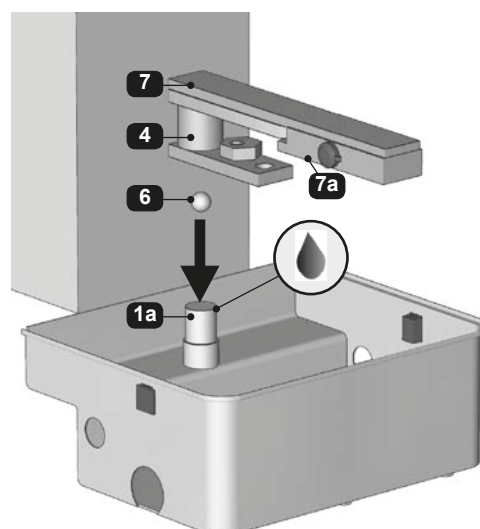

2c. Mounting of gate frame at the gate bearing

Installation

- The gate frame can be mounted directly to the gate bearing or by using an approx. 250 mm long guiding rail (U-profile).
In each case gate hinge and bearing pin have to be perpendicular to each other (point A and B) and the gate wing has to be mounted vertically.
- According to the way of mounting either connect the gate frame or the guiding rail with the gate bearing (7). **(Note: Take care that the emergency release (7a) still works properly!)**

If a guiding rail is used, insert the gate frame and adjust it vertically. Afterwards insert the limiting piece and weld it to the guiding rail. It is recommended, to weld the guiding rail not onto the gate frame!

It is recommended not to weld the guiding rail to the door!

Note: For a ground clearance of more than 55 mm please insert a spacer before mounting the gate/the guiding rail to the gate bearing.

- Checking the opening movement**

Emergency release the operator (see emergency release) and fully open and close the gate manually. Make sure that no undue friction occurs.

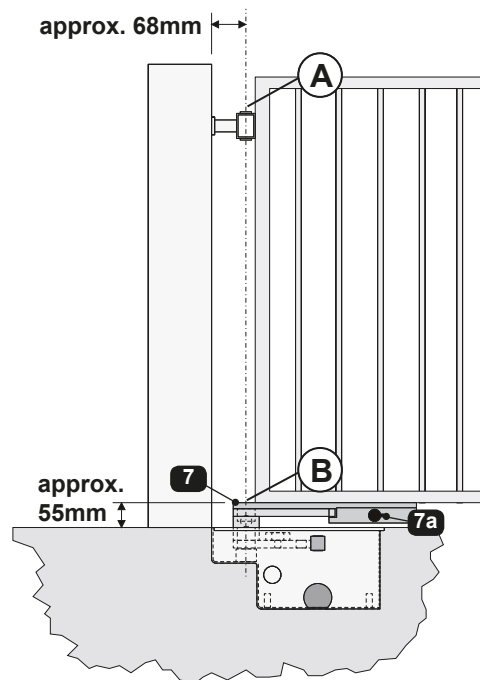

- Mounting without guiding rail**

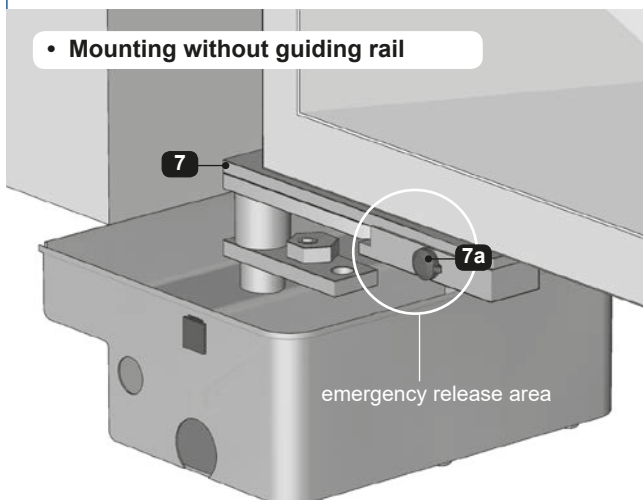

- Mounting with guiding rail**

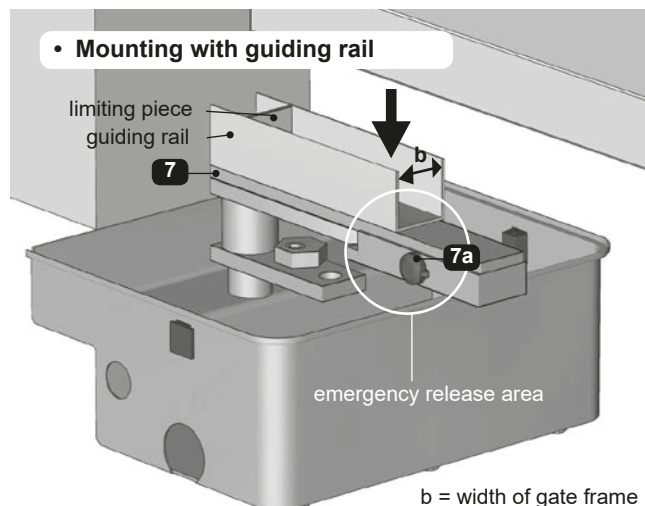

b = width of gate frame

2d. Mounting the motor-gearing unit

Installation

- Open the gate completely
- Pay attention to left- and right installation (see below figure). Put the motor-gearing unit onto the 4 screws inside the housing and secure it with the nuts.

left installation

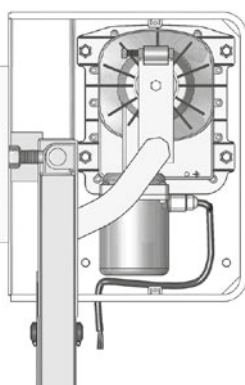

right installation

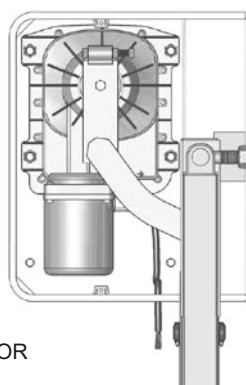

INTERIOR

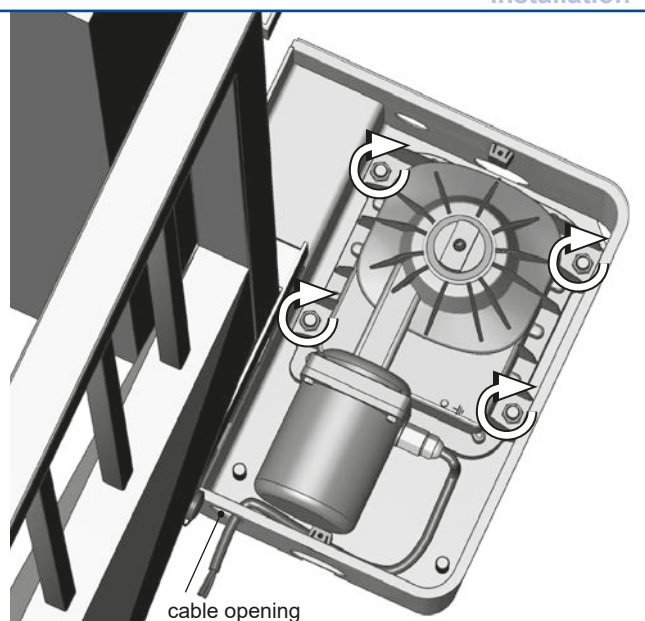

cable opening

Mounting of motor- and lever arm

- Put motor arm (3) onto gearing shaft (2b) and fix it with a screw.
- **Important: Grease the pins of the lever arm (5) properly!**
- Now turn the gate as far as the lever arm (5) can be inserted in the openings of the gate driver (4) and the motor arm (3). Please take care to insert the lever arm (5) as shown in the picture (the bending of the arm always points away from the gate axis, at left installation as well as at right installation).

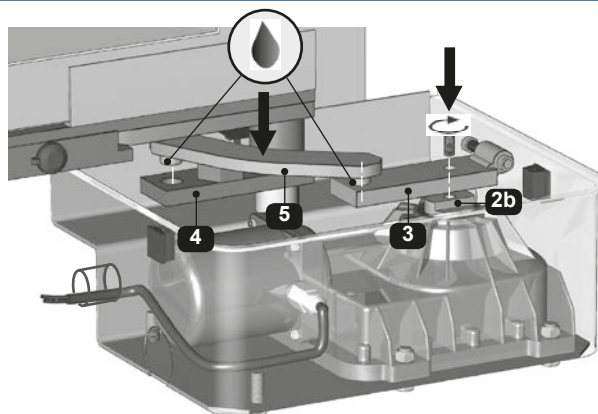

optional: mounting output pinion and chain (for turning angle > 110°)

- Set output pinion (K2) on gearing shaft (2b) and fix it with a screw.
- Now put the chain (K3) around the gate driver (K1) and the output pinion (K2) and close it with the chain lock (K3a).
- **Important: The chain has to be greased carefully!**

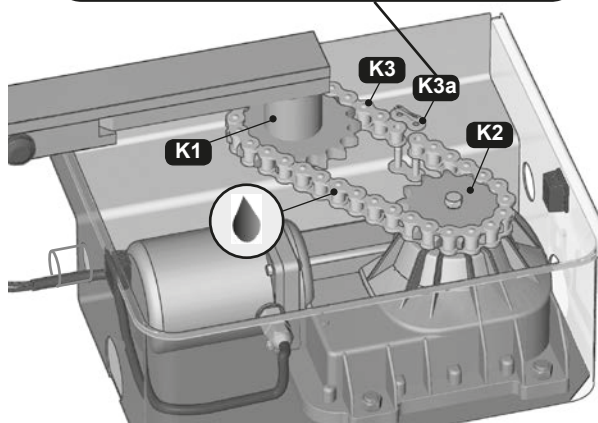
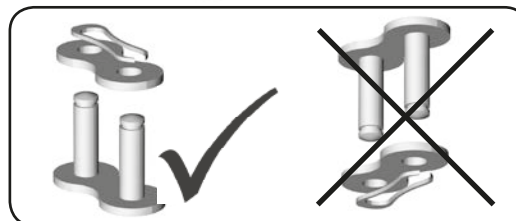

Important for chain operation

- Since the internal limits don't come into effect at chain operation you have to make sure, that floor stops fix the end positions gate opened and gate closed.
- Alternatively Tousek piston rod travel limiters can be used as well.

- Before carrying out the electrical connections the power supply of the swing gate facility has to be turned off.
- **Note: For the grounding the motor a separate grounding cable has to be laid.**
- Connect the operator according to the manual of the control. Therefore insert motor cable (blue/brown/black) (mk) and grounding cable (yellow-green) (ek) in a protective sleeve and lead it in the foreseen cable opening (1d).
The separately laid grounding cable is fixed directly at the motor block with the help of a screw (2a).
- Connect various safety devices and accessories according to their manuals (*please pay attention to enclosed cable plan*).
- The force adjustment of the operator is carried out at the control (see control manual).

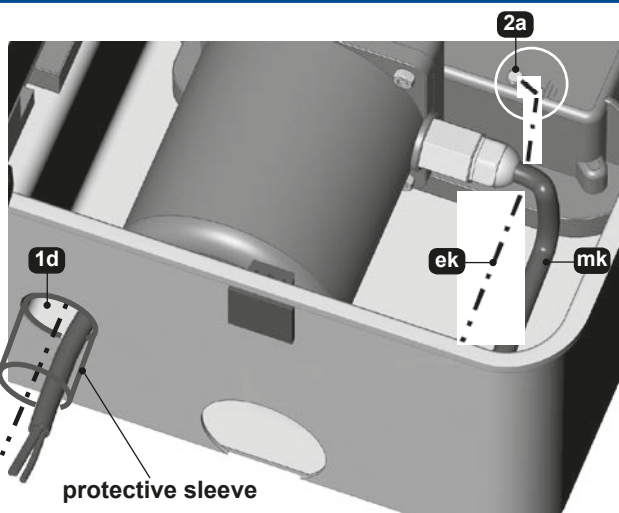

Attention

- At force adjustment please take care that all valid safety standards and regulations are kept.

| Connection to control ST 51 | | |
|-----------------------------|---------------|----------------|
| CABLE | LEFT operator | RIGHT operator |
| black | terminal 20 | terminal 26 |
| blue (common) | terminal 21 | terminal 25 |
| brown | terminal 22 | terminal 24 |
| yellow/green (grounding) | terminal 23 | terminal 27 |

2g. Adjustment of internal limiters (invalid for operators with chain: foresee external floor stops!)

Installation

Adjustment of limiters for OPEN position

- Fully open the gate with the operator
- Now turn the hexagon (4a = limiter for open position) at the gate driver so far (loosen fixing screw (4b)) that the lever arm (5) touches the hexagon.
- Fix the hexagon (4a) in this position with the fixing screw (4b).

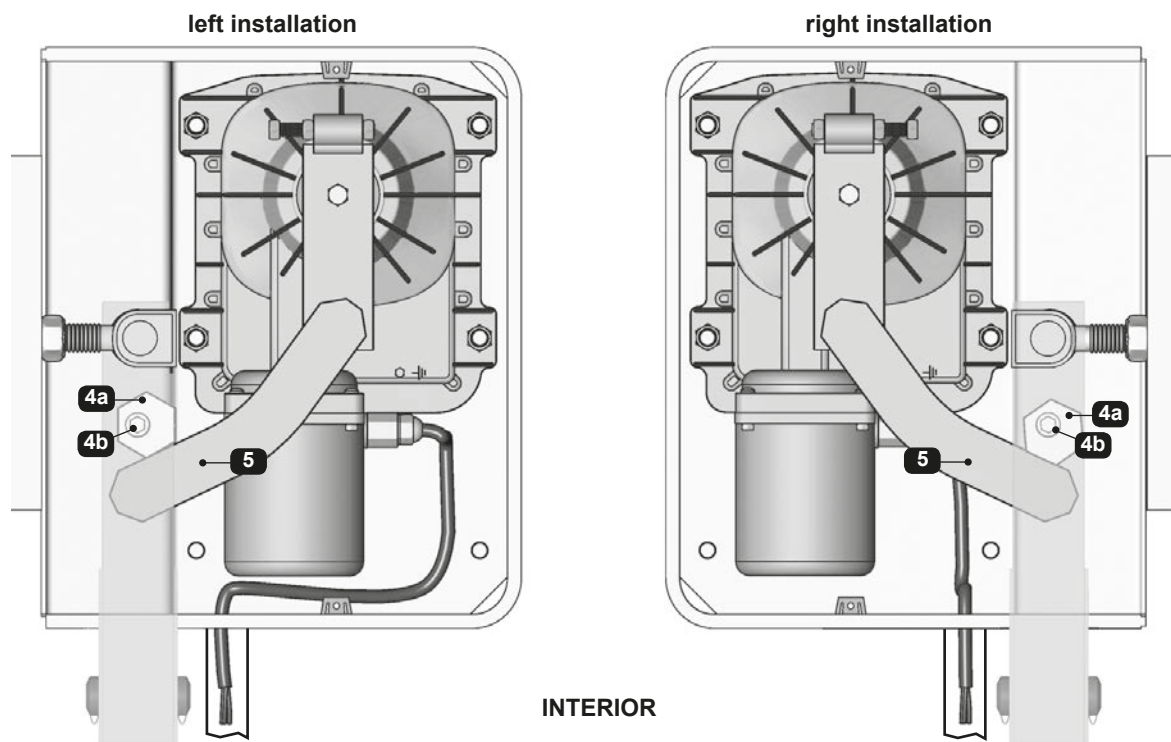

Adjustment of limiters for CLOSED position

- Fully close the gate with the operator
- Now turn the limiting screw (3b= limiter for closed position) at the motor arm (3) so far that it touches the lever arm (5).
- Depending on left- or right assembly, please take care that the limiting screw (3b) is correctly positioned in the guiding of the motor arm (3) (see picture).

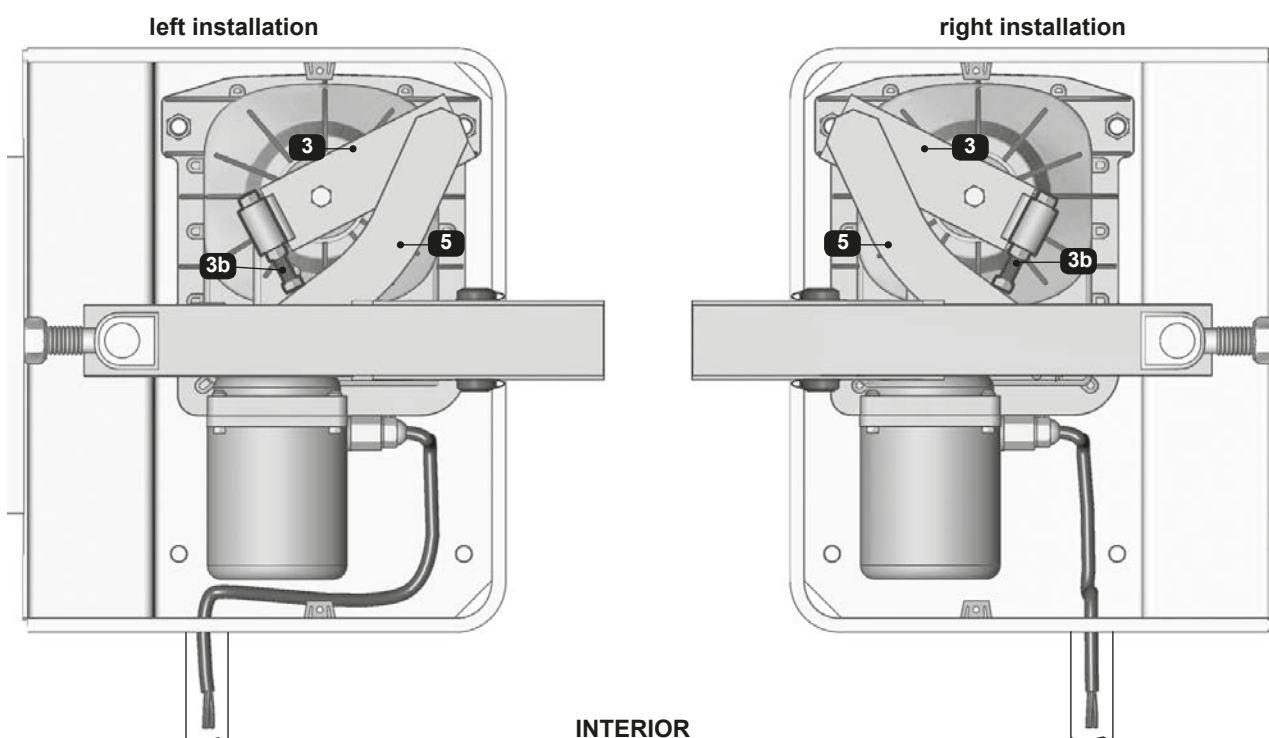

2h. Putting on the housing cover

Installation

- After finishing the installation- and adjustment works put the housing cover (8) on the underfloor housing and fix it with 2 screws (8a) in the intakes (8b) at the sides of the housing.
- Finally put on the plastic cover (9).



Note

- Before closing the housing please note the suggestion on page 5.

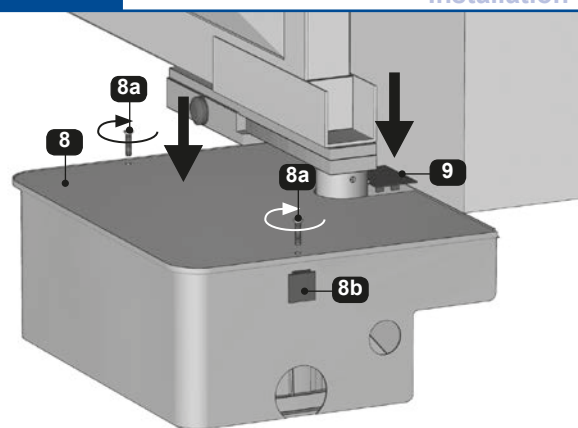

3. Note for the user - Emergency release (e.g. at power failure)

TURN 310 UF

In case of a defect or power failure the operator can be emergency released as follows:

- Turn off power supply!



- Open plastic cap at the emergency release mechanism (7a).
- Insert emergency release lever (7b) as shown in the drawing and turn it right till the gate bearing (7) is released of the gate driver (4). Keep this position and release the gate manually.
- To restore motor operation turn the gate until you can hear that it has re-engaged.
- Put on the plastic cap again.



Note

- Installation, connection, taking into operation and maintenance may only be carried out by qualified professionals and with regard to this manual.

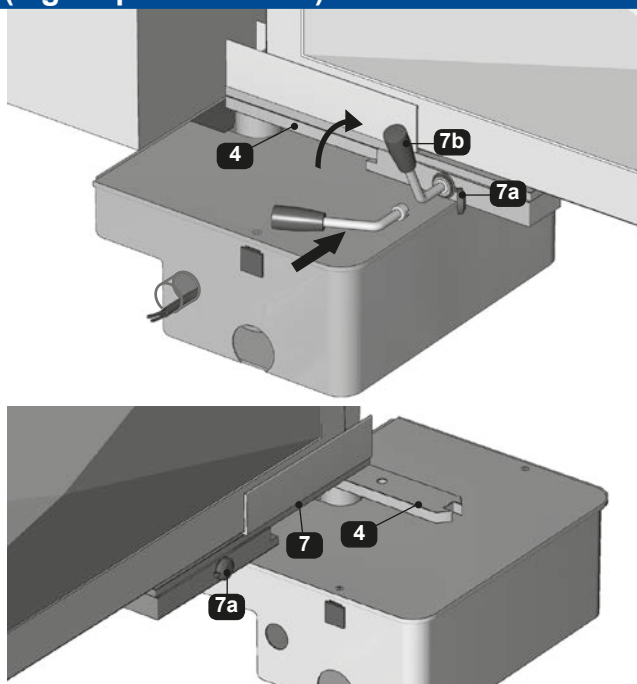

Before carrying out maintenance works at the gate-system, the power supply has to be turned off!



- All pivot- and bearing points have to be greased periodically.
- For greasing the pivot point of the operator, the cylindrical part of the gate driver (4) has to be foreseen with a tap hole. In this tap hole the grease nipple (4c) for connection of a grease gun is inserted.
- At the end of each winter season you should rinse the operator with warm water.

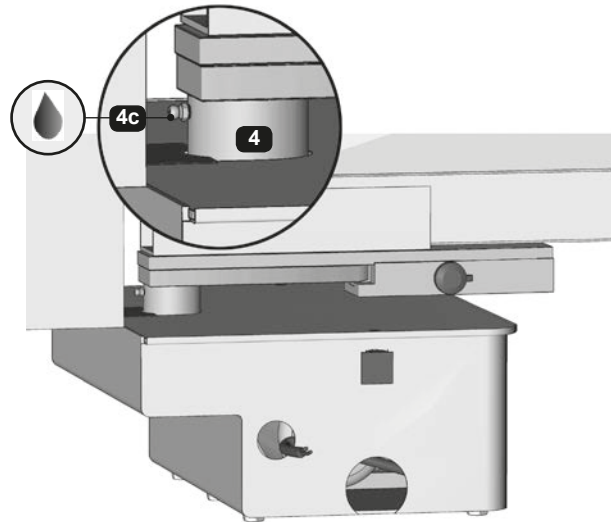

For allowing an adjustment of the e-lock (e.g. at thermal expansion of the gate) we recommend to mount the locking plate or the e-lock on a base plate with longitudinal slots.

Mounting the e-lock on double-wing gate

- recommended way of mounting:
Lock with knee joint (optional) art. code 14560200
 e-lock and locking plate are mounted at the according gate wings (see picture)

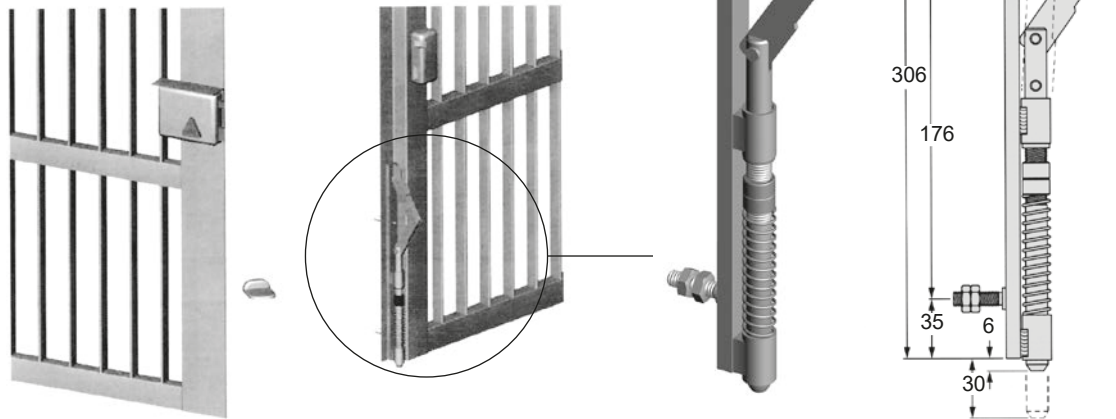

- Locking with e-lock:*
 The locking plate is mounted at the ground (limiter).

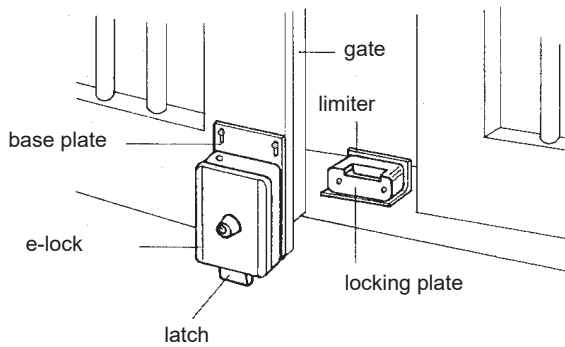

Mounting the e-lock at single wing gate

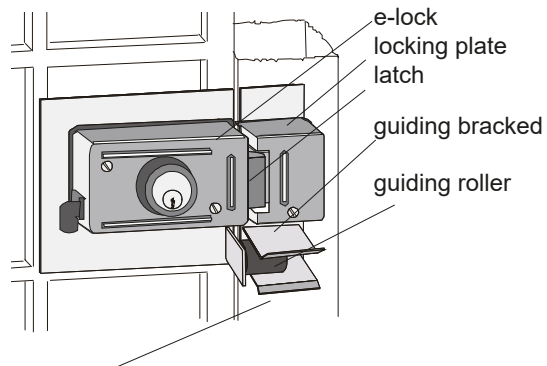

- Note:**
 For an optimal function of the gate facility we recommend to use a centering guide (optional) art. code 13800040

- 1 operator Tousek TURN 310 UF
 1a connection box
 2 electronic logic control
 (optional with integrated radio receiver)
 3 external antenna (for increased range)
 4 signal light
 5 external fotocell
 6 internal fotocell
 (T: transmitter, R: receiver)
- 7 main power switch and fuse 12A
 Note: An all-pole disconnecting main switch with a contact opening-gap of minimum 3 mm has to be foreseen.
 8 pushbutton momentary contact switch
 9 key-operated momentary contact switch
 10 safety sensing edges
 11 hinged locking bar
 12 electric lock

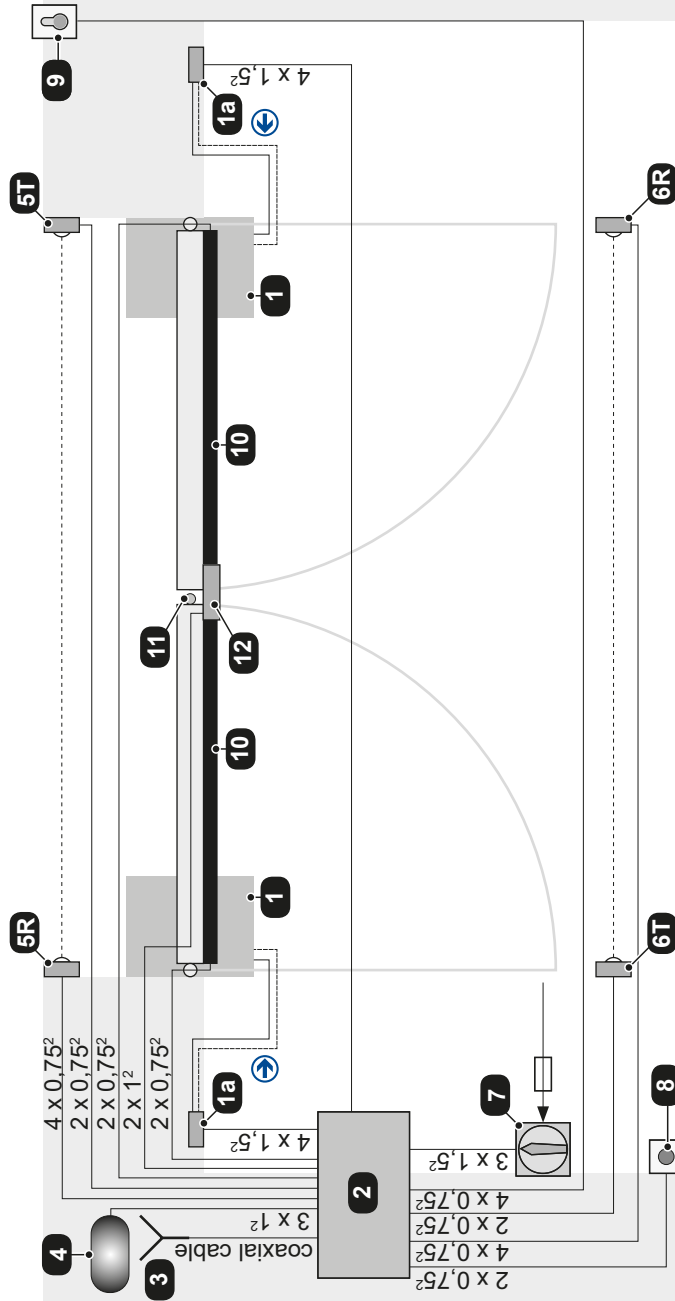

Note: The grounding cable has to be lead separately from the connection box to the motor.



NOTE concerning cable laying

The electric cables have to be laid in insulating sleeves which are suitable for underground usage. The insulating sleeves have to be lead into the inner of the operator housing.

230 V cables and control lines have to be laid in separate sleeves.

Only double-insulated cables, which are suitable for underground usage (e.g. E-YY-J) may be used.

In case that special regulations require another type of cable, cables according to these regulations have to be used.



SAFETY NOTE

Please be aware that the beside picture is only a symbolic sample illustration of a gate facility and may therefore not show all safety devices required for your specific application.

To achieve an optimum safety level at your gate facility, please make sure that all safety components and accessories which - according to the applying safety rules and laws - are required in your particular case (e.g. photocells, induction loops, sensing edges, signal lamps, traffic lights, mains- and emergency power off switches etc.) are properly installed, operated, and serviced.

In this context please follow the EU Machine Directive, accident prevention rules and laws, as well as applying EU- and national standards in force at the time of installation and operation of the gate facility.

The Tousek Ges.m.b.H. cannot be held responsible for any consequences resulting from disregard of applying standards and laws during installation or operation of the gate facility.

The 0,75mm² control lines are shown without ground lead. In order to facilitate connections we recommend using flexible wires and not using thicker wires for the control lines.

7. Dimensioned drawing (left operator)

Underfloor operator TURN 310 UF

- dimensions in mm

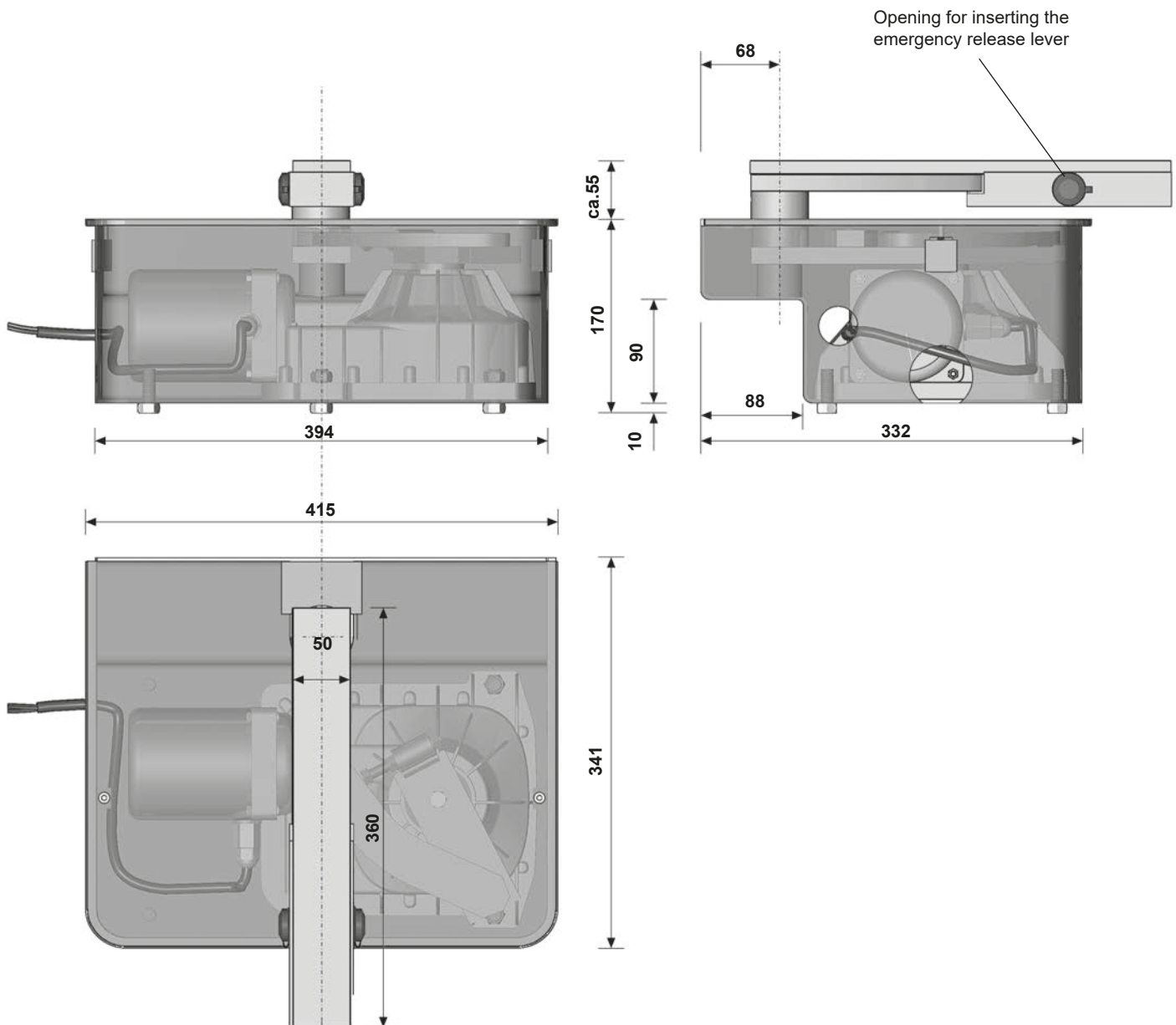

We reserve the right to change dimensions and technical specifications without prior notice.

tousek PRODUCTS

- sliding gate operators
- cantilever systems
- swing gate operators
- garage door operators
- folding door operators
- traffic barriers
- electronic controls
- radio remote controls
- key operated switches
- access control
- safety devices
- accessories

Tousek Ges.m.b.H. Austria
A-1230 Vienna
Zetschegasse 1
Tel. +43/ 1/ 667 36 01
Fax +43/ 1/ 667 89 23
info@tousek.at

Tousek GmbH Germany
D-83395 Freilassing
Traunsteiner Straße 12
Tel. +49/ 8654/ 77 66-0
Fax +49/ 8654/ 57 196
info@tousek.de

Tousek Benelux NV
BE-3930 Hamont - Achel
Buitenheide 2A/ 1
Tel. +32/ 11/ 91 61 60
Fax +32/ 11/ 96 87 05
info@tousek.nl

Tousek Sp. z o.o. Poland
PL 43-190 Mikołów (k/Katowic)
Gliwicka 67
Tel. +48/ 32/ 738 53 65
Fax +48/ 32/ 738 53 66
info@tousek.pl

Tousek s.r.o. Czech Republic
CZ-252 61 Jeneč u Prahy
Průmyslová 499
Tel. +420 / 777 751 730
info@tousek.cz

tousek
E_TURN-310UF_43000203
15. 04. 2019



your service partner:

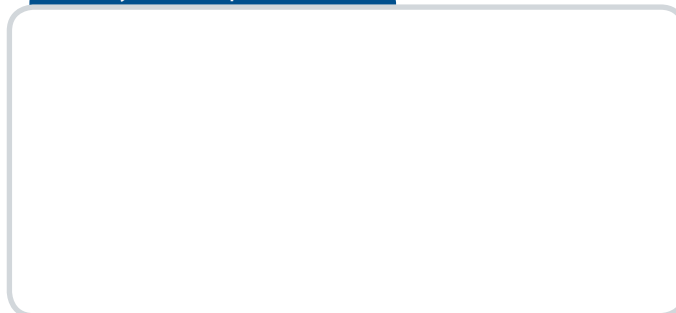

We reserve the right to change dimensions and/or technical specifications without prior notice. Claims resulting from misprints or errors cannot be accepted.

